

Part	Description	Quantity (Per Set)
A	M8 x 20mm – T-Nut Bolts	4
B	Mounting Rail	2
C	Base	2
D	T-nuts	4
E	Clamp Plate	2
F	Conical Washer	2
G	Locking Knob	2
H	M8 x 20 – Adjustable Arm Bolts	4

Three Length Settings

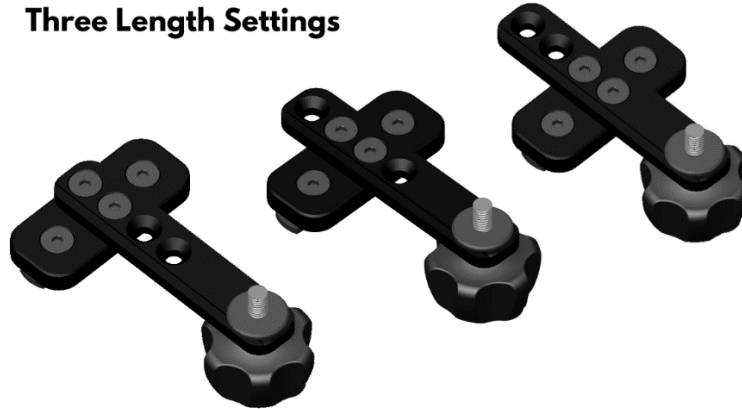

Installing your CRC System using Trxstle's T-slot Mounting Adapter Kit

- 1) Before beginning installation:
 - a. Decide where you want to position your CRC System on your vehicle.
 - i. Check for hatch clearance and compatibility with any other rooftop accessories you have installed on your vehicle.
 - b. Ensure that you can access the point of insertion for the T-slots on your cross bars. Refer to your rack manufacturer for information on how to use T-slot nuts with your specific rack system. (Figure 1A)
 - c. To ensure the locking knob has sufficient clearance to turn freely when installed on your crossbar, set the length of your T-slot mounts using the two center bolts (H) to extend or shorten the mounting arm as needed. (Figure 1B)

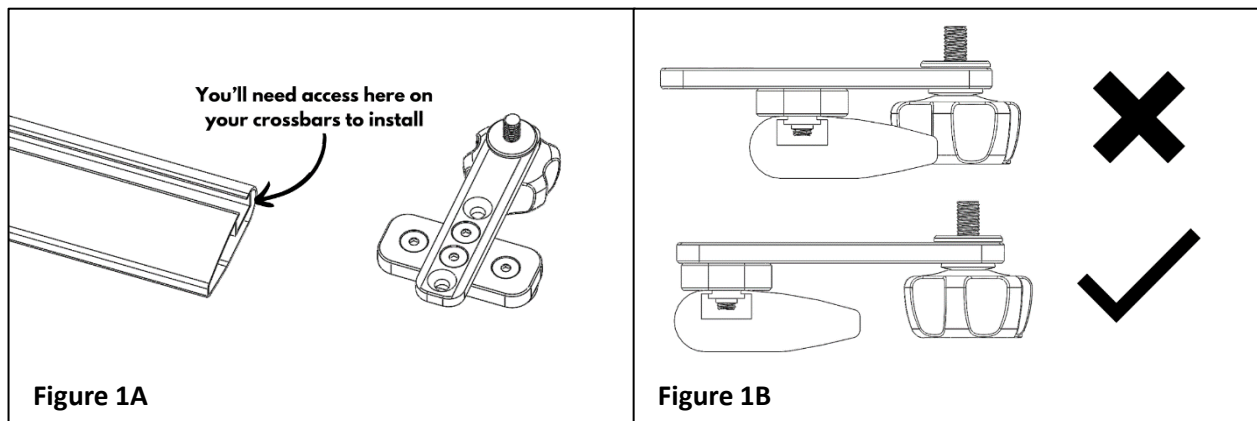

- 2) The T-nuts included with the *Trxstle T-Mount Adapter Kit* are universal in nature and they will work with the vast majority of aftermarket and OEM crossbar racks. If you have trouble fitting the included T-nuts on your rack, please contact support@trxstle.com

- 3) To begin the installation, loosen the two T-slot nuts on the bottom of each *T-Mount Adapter Kit* by rotating the T-Nuts counterclockwise. Loosen enough to slide into your crossbar's t-slot track smoothly and without resistance. Do not fully remove (Figure 2).

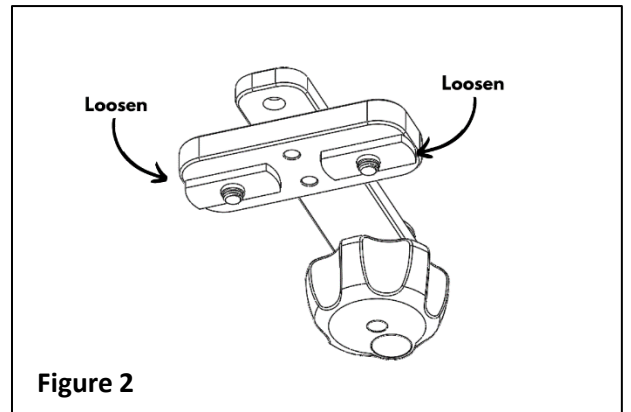

- 4) Next, slide the Trxstle T-slot mount Adapter into the T-slot on your rack's crossbar (Figure 3).
- 5) Once the T-slot mounts are positioned where you want them, tighten down the two (2) M8x 20mm flat head cap screws to secure the Trxstle T-Mount Adapters to your crossbar using a 5mm Allen Wrench (Figure 4).
 - a. Torque Spec: 24Nm / 18lbft

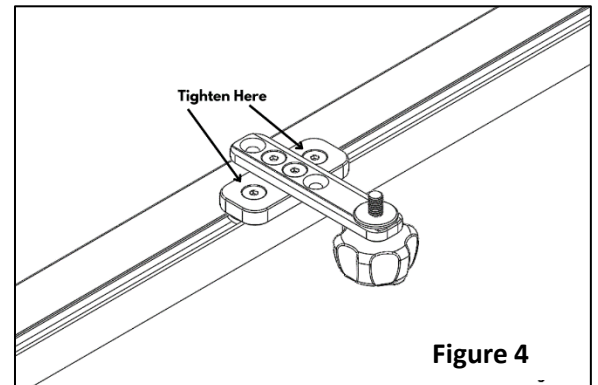
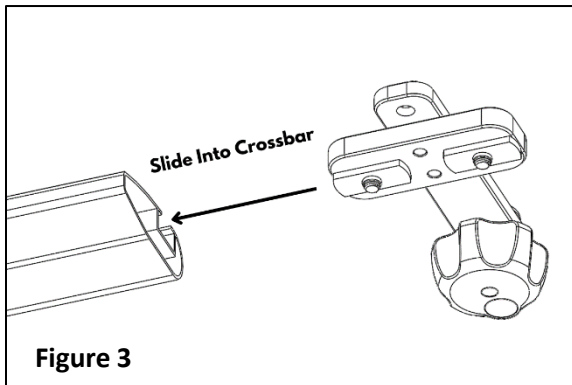

- 6) Double-check that your mounts are aligned so that the CRC System will be straight on your vehicle. (Crooked rod carriers will drastically reduce street cred.)
- 7) Loosen the locking knob on the mounts and check to ensure the conical washer is oriented as shown. If the washer is not in this orientation, reverse it to match (Figure 5).

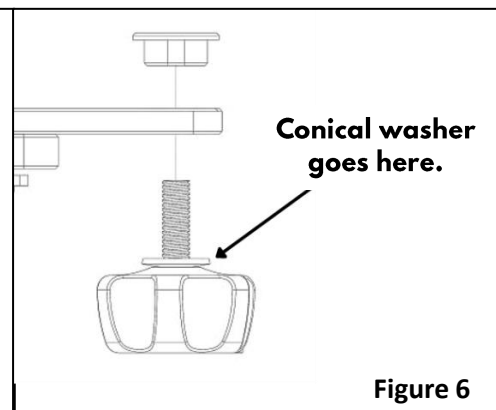
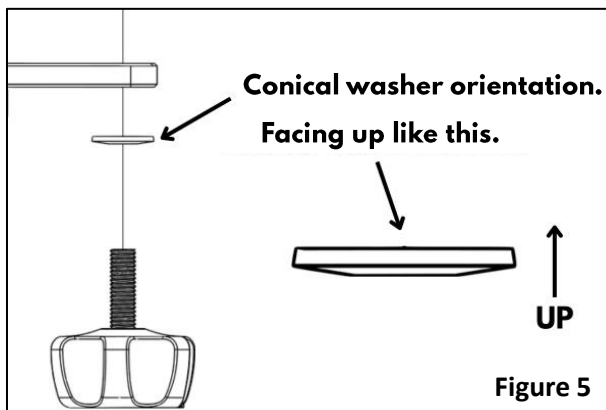

- 8) With your CRC System extended and ready to mount, lift the CRC Rod Carrier on top of your vehicle and slide the T-Slot Mount Adapter **Clamp Plates** into the desired T-Track slots of your CRC System (Figure 7).
- You may need to loosen the knob of the T-Mount Adapter Kit to allow for the clearance needed to slide the Clamp Plate into the CRC System's T-Track slots.
 - Note: The Clamp Plate can only be inserted into the CRC System T-Track slots using the wider opening of each slot on the bottom of the CRC System (insertion opening).

- 9) **IMPORTANT**** Check to make sure that the T-nuts in the CRC System slots do not overlap with the insertion opening and are completely in the T-slot track on the CRC.

- 10) Tighten down the locking knob to secure the CRC System. Please note that the knobs have a built-in torque limiter to prevent over-tightening (Figure 8).

- 11) To lock the knob, insert the key and turn 180 degrees. The knob will rotate freely when locked without loosening the clamp plate.

- 12) Go Fish.

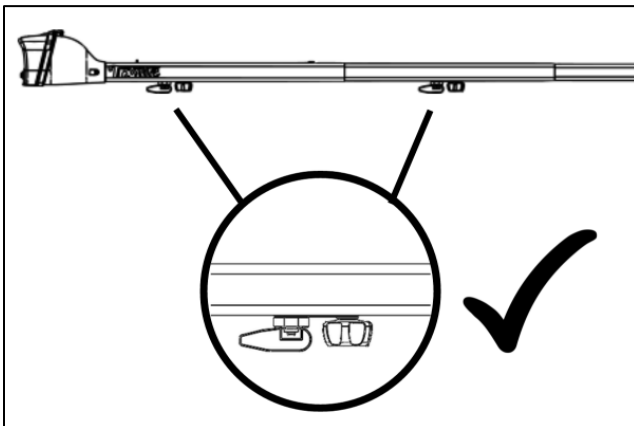
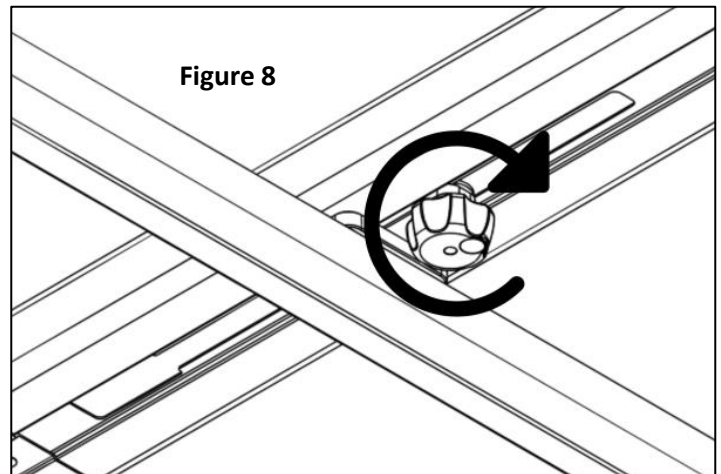
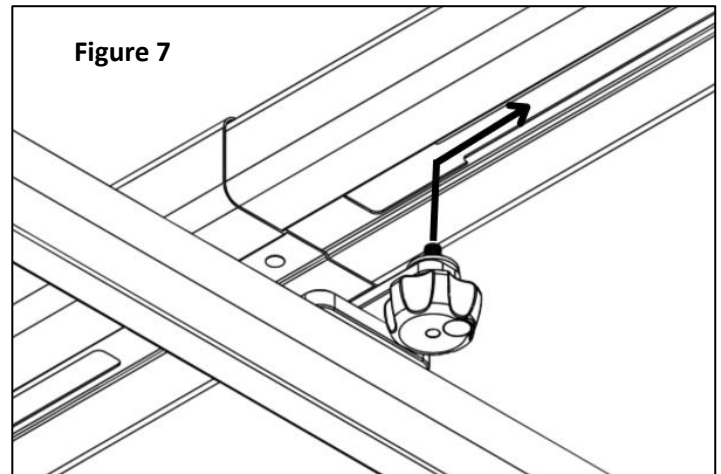

Questions? Comments? Something not making sense?

Call us: 406-202-3500

e-mail us: support@trxstle.com